

Emergency-stop/switch-off devices - mounting & operating instructions (Translation of the original operating instructions)

V5.6, 21.05.2026, art.-no.: 615409900



- All rights reserved -
- The product properties and technical data stated therein do not represent any warranty -

1 About safety

1.1 **⚠ Safety regulations:** This operating instructions must be provided to the person who installs the emergency-stop device. Please read it carefully and keep it for future reference.

Ensure that emergency-stop devices are only installed and put into operation by specially trained, authorised personnel.

For customised types the information in the data sheet has to be considered as well.

1.2 **Application:** Schlegel emergency-stops/switch-off devices are electromechanical switch components to protect persons working with machinery or close to it. They are used to stop or switch off machinery and equipments in order to avert impending or minimise existing dangers to persons or damages on machines/material.

The following (inter)national statutory provisions apply to installation, commissioning and regular technical inspections:

- Machinery directive 2006/42/EG *6)
- Machinery regulation 2023/1230/EU *7)
- Low-voltage directive 2014/35/EU
- Safety regulations as well as
- Regulations of the accident prevention/safety rules.

Manufacturers and operators of machines using emergency-stops should retain the responsibility for the adherence of these instructions as well as for compliance with the relevant safety regulations and rules.

For the application of emergency-stops as directed the respective requirements for installation and operation must be observed:

- EN60204-1
- EN13849-1
- EN ISO 13850

Contact blocks are suitable for applications up to PL e acc. to EN ISO 13849-1 and up to SIL CL 3 acc. to EN IEC 62061.

- ⚠ Disconnect equipment and device from the mains before installation!
- ⚠ Emergency-stops fulfil the function of human protection. Improper installation or unauthorised modifications may lead to severe personal injuries!
- ⚠ Emergency-stops should not be bypassed, removed or otherwise disabled!
- ⚠ The switching operation should only be triggered by means of appropriate emergency-stop heads which are securely connected to the contact block!
- ⚠ Suitable connectors to be used with the contact blocks.
- (!) Improper installation or tampering may result in machinery and material damage!
- (!) The emergency-stop function should not replace the applicable safety precautions or other safety functions but should rather be used as a back-up safeguarding measure.
- (!) The emergency-stop function should not impair the effectiveness of other safety devices or equipment with other safety functions.

(!) Based on the hazard analysis the design engineer must ensure that in combination with the control system the emergency-stop meets the required safety category.

(!) When using emergency-stops with key release the key must only be inserted during the release procedure.

1.3 Approvals and technical data:

Refer to the catalogue information of the respective emergency-stop and contact block, the data sheet resp. the online product configurator under <https://www.schlegel.biz/en/>.

Unless otherwise stated in the data sheet, the altitude of the place of use may not be more than 2,000 m above sea level.

2 Product description

2.1 **Construction:** Emergency-stop devices consist of variants of emergency-stop heads and one or more contact elements. They are available for front panel mounting or base-plate mounting in an enclosure. They are operated by pressing the button.

Features: The emergency-stop heads differ in

- their mode of release: rotation to the left or to the right or only to the right; key release by rotation to the right; pull release, twist/pull release
- the shape of the protective shroud/anti-lock collar (also illuminated option)
- illumination: illuminated/non-illuminated
- the protection system: emergency-stop heads for standard application and emergency-stop heads which can be used in the food industry due to their outer face acc. to DIN EN 1672-2 and DIN ISO 14159 subject to the mounting conditions as per paragraph 8 „Further operating instructions for hygienic areas“. The contact blocks are modular or in monoblock design and can be supplied with different connection types (screw type, spring cage, push-in connection, Faston and PCB-mounted terminals).

2.2 Emergency-stops and contact blocks

Emergency-stops	Ø	Contact blocks
OKJ(B)UV, OKJVL, OKJVL_KL	23.1 x 23.1	AZOSOI(_AU), AZ2N(_AU), AZSOSO(_AU), AZ(L)4O(_AU), BZ(L)O(5)(K)(_AU), BZ(L)OO(5)(K)(_AU), BZ(L)OI(5)(K)(_AU), BZ(L)OS(5)(K)(_AU), PTF(OO)(OI)(_AU), PTF(OO)(OI)(_AU), PTFP(OO)(OI)(_AU), FRTF(P)(L)(OI)(OO)(S)(OI)(OOI)(3O)(_AU)
RKUV(28)(GB), RKVL28, RKVL28_KL	16	AT(_AU), AZ011(_AU), AZ00(_AU), AZ(L)4O(_AU), AZ(L)2(_AU), AZ2N(_AU), AZOSOI(_AU), AZSOSO(_AU)
OKUVGB		
RKUV(32)(40)(_496)		
RKUVGB		
XFV32	22	ETR; MTO, MTI, MTO_545, MTI_545, MTOSF, MTOSFE; MKPTI, MKPTO, MKTI, MKTO, MK(P)TOSFE; DTO, DTI, DSTO, DSTI, DMTOSE, DMSTOSF,
RRJUV, RRJVL, RRJVL_KL		
RX(B)(SK)(L)UV(SE)(P)	16	
XFV32	24 x 24	
QXJ(B)UV		
RXJ(B)UV	22	
QRUV(P)	22	
QR(B)(SK)(L)UV(SE)(70)(631) *4)		
QRV *2)		
RV(32) *2)		
RUV		
QRJUV	26 x 26	

Emergency-stop/switch-off devices - mounting & operating instructions

(Translation of the original operating instructions)

KRV *2), KR(J)(B)UV(70)	30	DSTOSDE - MT..., MK..., DT..., DS... can be combined within their own type series, see 3.7 Accessories: MAL(_V001), MHR_3, MHR_5, DMR, DSAL, MKAL, MKHR_3, MKLED24W, MKPAL, MKPLED24W
FRVK(L) FRVKAL...	22	PTOO(_AU), PTS(L)(OOO) (OO)(OO)(O)(L)_AU), PTSFP(L)(OOO)(OOI) (OO)(O)(L)_AU (L)_RO (L)_698)
Emergency-stops	Ø	Contact blocks
FRUV(L)	22	PTOO(_AU), PTS(L)(OOO) (OO)(OO)(O)(L)_AU)
FRUV33_NEU FRUVDG_NEU *2)	22	PTOO(_AU)
YV (O)(OO)(H) (LO)(LOO) (OOI) (L)_AU (L)_RO (L)_674)*3)	16	Emergency-stops with integrated contact block
YVO_V001 *2)	16	Emergency-stops with integrated contact block
FR(Z)(P)(K)VK (AL) (P) (L) (R)(Y1)(Y2)(O)(OO) (OOO)(3O)(O)(OOI) (OOI)(S)(P)(Z)(LZ) (L)_AU(L)_RO (L)_698) *3)	22	Emergency-stops with integrated contact block
FR(Z)(P)VK (AL) (P)(L) (R)(Y1)(Y2)(O)(OO) (O)(OOI)(S)(P)(Z)(LZ) (L)_AU(L)_RO)_C001 ...C999	22	Emergency-stops with integrated contact blocks and M12 connector
FR(Z)(P)VK (AL) (P)(L) (R)(Y1)(Y2)(O)(OO)(OI) (OOO)(3O)(OOI)(S)(P) (Z)(LZ)(L)_AU(L)_RO)_M001 ...M999 FRVKOO_MV001	22	Emergency-stops with integrated contact blocks and M12 connector with cable
KRVK(L)4O(P)(L)_AU)	30	Emergency-stops with integrated contact blocks
KRVK(L)(R)(Y1)(Y2) (O)(OO) (OI)_C001 ...C999, KRVKOO_1043_C001	30	Emergency-stops with integrated contact blocks and M12 connector
FR(Z)VK(Z)(AL)(L)(Y1)(P) (L)_698)	22	Only emergency-stop heads
QR(SK)(B)(L)UV(OO)(OI) (OOI)(OOO)(S)M12	22	MTO, MTI, MTO_545, MTI_545, MTOSF, MTOSFE
QR(SK)(B)(L)UV(SE)(43) (7O)(O)(OO)(OI)(OOI) (OOO)(L)_C(z)yxx, QRBLUV001_C1190, QRBLUVSEOO1C1190	22	Emergency-stops with integrated contact blocks and M12 connector
KRBUVOO_Mxx	30	Emergency-stops with integrated contact blocks and cable with M12 connector
KRBUVOO_KDxx	30	Emergency-stops with integrated contact block and cable with Deutsch connector

Emergency-stops	Ø	Contact blocks
OKVGB	16	FRT(OO)(LO)(O)(OI)_Cyxx

RKVGB; RKVL28; RKUV28		y...variant, xx...pin assignment, 4 poles
OKJBUV, OKJUV, OKJVL	23.1 x 23.1	FRT(OO)(OOI)(LOO)(LO) (O)(OI)_Cyxx
RRJUV, RRJVL	22	y...variant, xx...pin assignment, 5 poles
Emergency-stops	Ø	ASI-Safety at Work
OKJ(B)UV	23.1 x 23.1	ASI_SAW16A ASI_SAW16E ASI_SAW16
QXJ(B)UV	24 x 24	
RKUV(28)(GB) RX(B)(SK)(L)UV(SE)(P) RKUV(32)(40)(L)_496) XFV32 RKVGB	16	ASI_SAW22A ASI_SAW22E ASI_SAW22
RXJ(B)UV RRJUV	22	
QR(B)(SK)(L)UV (SE)(70)(631) *4) QRUV(P)	22	ASI_SAW22A ASI_SAW22E ASI_SAW22
QRV *2)		
RV *2)		
RUV *2)		
QRJUV	26 x 26	
KRV *2), KR(J)(B)UV(70)	30	
ASI_SAW16A, ASI_SAW22A, with failure switch-off and digital output for illumination		
Accessory for emergency-stops: Protective shroud *4) RSK(F)22: for RRJUV, FRVK... RRSK: for FRVK... RKSK: for RKUVGB, RKUV28 Enclosure SIL(H)(22/1)(16/1): Enclosure		

3 Assembly and commissioning

3.1 Assembly instructions for front-panel mounting

- 1) Provide the required mounting hole in an appropriate mounting plate (refer to the relative catalogue drawings); in order to ensure full tightness of the unit, make sure to have a smooth surface, particularly in case of hygienic areas and emergency-stops with protective shroud.
- 2) For emergency-stops with illuminated anti-lock collar provide a second hole following the relative assembly drawings in the catalogue (Fig. 2).
- 3) Insert the emergency-stop in the cutout.
- 4) Fasten the emergency-stop with the plastic nut (please consider the max. tightening torque, see 10, table 1).
- 5) Snap-fit the contact block (MT..., MK..., DT..., DST..., DMS..., DMT..., ET...) to the neck of the emergency-stop by rotary motion (Fig. 3a, 3b) or snap-fit the contact block (AT..., BT..., PTF..., FRTF...) by pressing (Fig. 6, 7, 8).
Exceptions: The contact blocks of the type series FRTF... are set onto the emergency-stop and fixed by a small locking bolt (Fig. 9) through a hole in the PCB. *5)
The contact blocks PTSFP... must be snap-fit to the emergency-stop neck (inseparable).
The contact blocks PTOO.. and PTS.. are plugged into the neck of the emergency-stop FRUV(L) resp. FRVK(L). *5)
(Fig. 4, base-plate mounted version)

Emergency-stop/switch-off devices - mounting & operating instructions

(Translation of the original operating instructions)

V5.6, 21.05.2026, art.-no.: 615409900

The contact blocks FRT..._Cyxx are plugged into the neck of the emergency-stop.

(Fig. 11, FRT connect)

- 6) (!) Check whether contact block and emergency-stop are snap-fitted correctly.
- 7) Modular contact blocks (MT..., MK..., DT..., DST...) must first be correctly aligned and snapped into a module holder before snap-fitting them to the emergency-stop. (Fig. 1, 12, 13, 14, 15).

In order to ensure the fool-proof safety feature, a maximum of 3 contact modules may be used. (Remark: Each module of the types MTOSF, MTOSFE, MK(P)TOSFE and DSTOSDE counts as one single module)

Exception:

- 4 contact modules MT..._545
- 3 contact modules MT..._545 + 1 MTOSFE

- 8) Connect contact blocks.
- 9) For emergency-stops with illuminated collar put the plug for lighting through the relative hole in the mounting plate and connect it to the emergency-stop. (Fig. 2 and 3a)
- 10) ⚠ For emergency-stops with pre-assembled M12 connector with cable or integrated M12 connector a sufficient strain relief must be provided. There may not be any load on the device connection. Mounting and device connection see fig. 10.
- 11) ⚠ Pay attention to a sufficient bending radius of the cable so that there is no load on the cable connection of the emergency-stop.

3.2 Enclosure version

- 1) Mount lower enclosure part on an appropriate surface.
- 2) See 3.1, steps 2 to 9.
- 3) Insert wiring cable in the enclosure or rather connect it to the enclosure.
(!) Make sure that the contact blocks used in the enclosure are connected correctly in order to comply with the clearance and creepage distance requirements for insulated enclosures on proper use.
- 4) Close the enclosure.
(!) Make sure to have the enclosure closed tightly (tighten all screws...).

⚠ Make sure that the emergency-stop is always easily accessible. This particularly applies to emergency-stops with high protective shroud! ^{*4)}

4 Testing before first operation:

Mechanical test: emergency-stop latches when operated
Electrical test: machine stops / switches off when operated

5 Regular technical inspection

- Based on the risk assessment, the machine designer has to determine the inspection interval. It is, however, recommended that the competent safety officer activates and tests the emergency-stop at least once a year to ensure its proper functioning.
- mechanical and electrical functional testing acc. to paragraph 4
- secure mounting
- no visible unauthorised modifications or damages
- no loose connections
- replacement of the emergency-stop if it is no longer recognisable as such due to fading colours.

6 Dismounting:

⚠ Before dismantling disconnect equipment and device from the mains!

7 Incident operating instructions:

⚠ Mechanical overload or external impact damage may impair the function of the emergency-stop. Make functional tests as mentioned under 5.

8 Further operating instructions for hygienic areas:

The following emergency-stops are among others also suitable for use on machines in the food industry, splash zones as well as for non-food areas (definition acc. to DIN EN 1672-2 and DIN ISO 14159):

- QRUVF
- RXUVF
- FRVKP...

For those applications the following has to be considered:

Operational conditions:

Operating temperature: -30°C up to +50°C (short-time up to +70°C)

A continuous contact with hydrocarbon (e.g. petrol, oil, grease etc.) has to be avoided.

Limited UV resistance, a continuous outside application without additional protection is not recommended.

Mounting:

The emergency-stops are designed for the installation in an enclosure or switching cabinet onto a plain, preferably metallic, surface (e.g. front panel).

Prior to the assembly the sealing lip of the yellow flexible collar has to be greased with the supplied grease, e.g. with the finger. Please wear gloves made of nitrile rubber. The excessive grease has to be removed without damaging the sealing lip.

Ansicht B

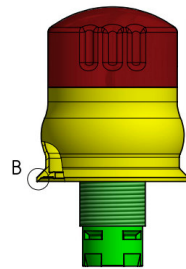
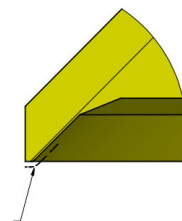

Grease surrounding edge!

Mounting is possible for a material thickness of 1 to 4.5 mm for FRVKP, from 1 to 6.5 mm for QRUVF and from 1 to 7 mm for RXUVF. Please consider the recommended tightening torque for the fixing nut as stated in table 1.

A mounting grid of at least 50 mm between the outer edges of the emergency-stops has to be kept in order to allow an easy cleaning between the buttons.

We recommend an appropriate mounting position, preferably for horizontal operation in order to allow a flow off of liquids in the non-operated as well as in the operated condition (fold).

Cleaning/Disinfection:

Clean in general

- prior to first operation,
- when necessary (depending on pollution degree),
- periodically (acc. to your internal cleaning schedule).

If the surface became dirty by oil or grease containing substances they have to be cleaned immediately.

All outer surfaces of the emergency-stops (QRUVF, RXUVF, FRVKP) are suitable for wet cleaning and disinfection.

We recommend the use of usual low concentrated cleaning and disinfection agents with a low acidity.

Cleaning and disinfection agents in highly concentrated solutions are not suitable.

Emergency-stop/switch-off devices - mounting & operating instructions (Translation of the original operating instructions)

V5.6, 21.05.2026, art.-no.: 615409900

Use for the cleaning/disinfection, if necessary,

- Cleaning utensils which are clean and of satisfactory hygiene condition.
- Cleaning utensils which do not absorb any elements to the surface to be cleaned (e.g. clean and fluff-free cloth).
Do not use for cleaning/disinfection:
- Sharp, hard or pointed object (e.g. steel wool and steel brushes) which can damage the surface.
- Abrasive treatments which negatively affect the surface roughness of the material.

The use of high pressure cleaners for cleaning/disinfection is not recommended.

Please note the following:

Check all outside visible parts from time to time and after operation. In case of damages the emergency-stops have to be exchanged by equivalent hygienically designed units.

9 Note for use of "protective shrouds"

- ⚠ The user must check the accessibility.

10 Tightening torques

Table 1: Tightening torques for the fixing nuts

Emergency-stops	Tightening torque	
	min.	max.
Emergency-stops with 16 mm housing neck		1.5 Nm
Emergency-stops with 22 mm housing neck		2.5 Nm
FRVK...	1.3 Nm	1.9 Nm
FRVK...C, M...	1.0 Nm	1.7 Nm
KRVK...	1.2 Nm	2.0 Nm
KR(B)UV...	1.2 Nm	2.2 Nm
Hygienic areas		
RXUVP	1.0 Nm	1.3 Nm
QRUVP	1.5 Nm	2.2 Nm
FRVKP...	1.0 Nm	1.7 Nm
M12 connector: connect and M12 versions		0.4 Nm

11 Disposal:

The proper disposal as per the national regulations and laws is obligatory.

12 EC declaration of conformity:

(Download of the operating instructions under <https://www.schlegel.biz/en/service/download-area>)

Name/address of issuer:	Georg Schlegel GmbH & Co. KG, Kapellenweg 4, 88525 Dürmentingen		
Responsible for documentation:	Georg Schlegel GmbH & Co. KG, Kapellenweg 4, 88525 Dürmentingen		
Product descriptions:	Emergency-stop/switch-off devices		
Type references:	Refer to above table 2.2		
The specified products comply with the provisions of the following directives / regulation(s):			
Directive/regulation:	of:	applied norms:	for:
2006/42/EG	*6) 17.05.2006	DIN EN 60947-5-5: 2017-08	contact blocks, emergency-stop heads, ASI-Safety, protective shroud
2023/1230/EU	*7) 14.06.2023	EN ISO 13850:2015 (D)	
2014/30/EG	26.02.2014	IEC 62026-2:2019	ASI-Safety

- *1) -
- *2) ensure to have a yellow background, e.g. by using a yellow nameplate NAS... (accessory)
- *3) versions with Faston terminals: use partially or all-insulated Faston clamps; illuminated versions (24 V LED) or versions with 3 contacts: overvoltage category II (2.5kV), pollution degree 2
- *4) see paragraph 9, note for use of "protective shrouds"
- *5) space sleeves ensure the correct distance between PCB and mounting plate.
- *6) valid until 19th of January 2027
- *7) valid from 20th of January 2027

Emergency-stop/switch-off devices - mounting & operating instructions

(Translation of the original operating instructions)

V5.6, 21.05.2026, art.-no.: 615409900

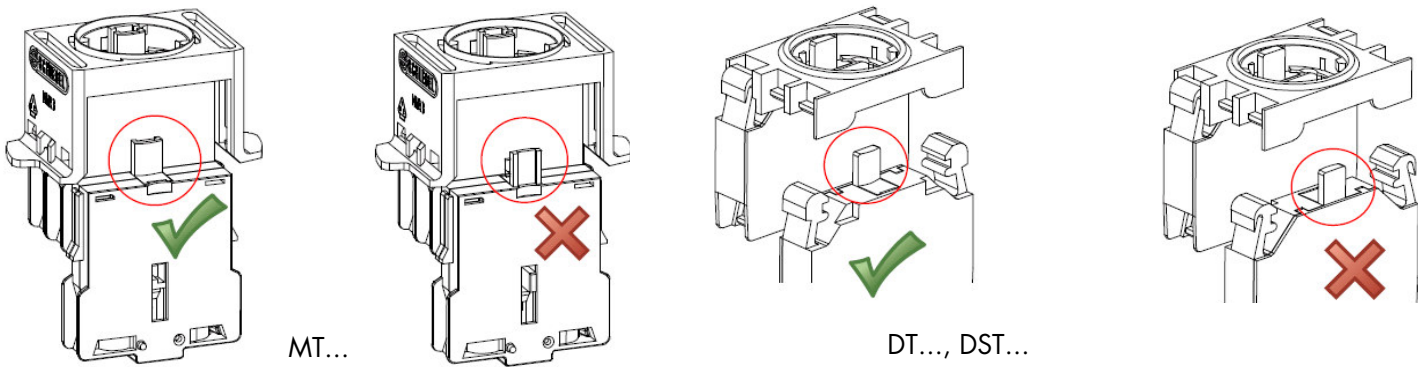

Fig. 1: correct assembly of the modular contact blocks MT..., DT..., DST...

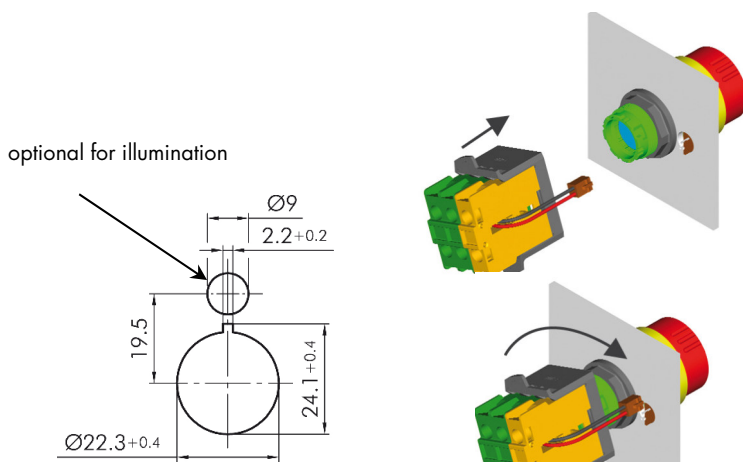

Fig. 2: mounting hole for emergency-stop (22mm)

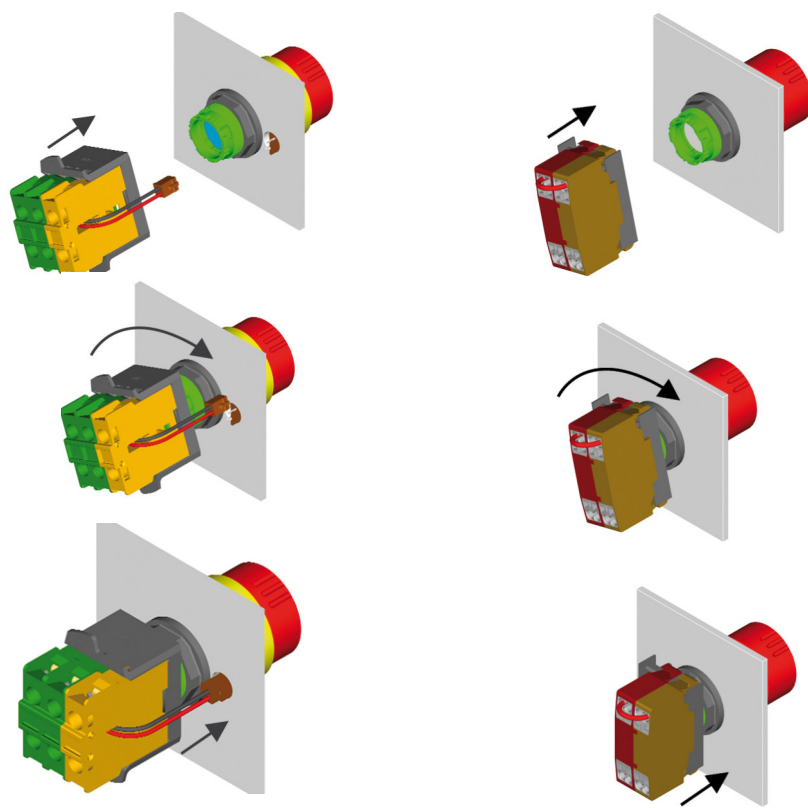

Fig. 3a: assembly drawing MT...

Fig. 3b: assembly drawing MK..., DT..., DST..., DM...

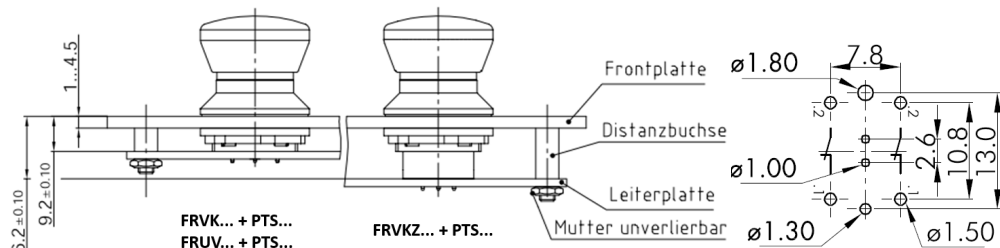
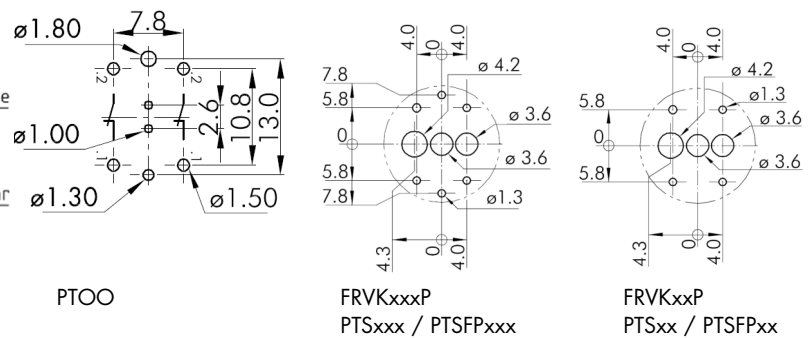

Fig. 4: assembly drawing, base-plate mounted version FR...



PTOO

FRVKxxxP
PTSxxx / PTSFPxxx

FRVKxxP
PTSxx / PTSFPxx

Fig. 5: hole pattern (x ... L, O, I)

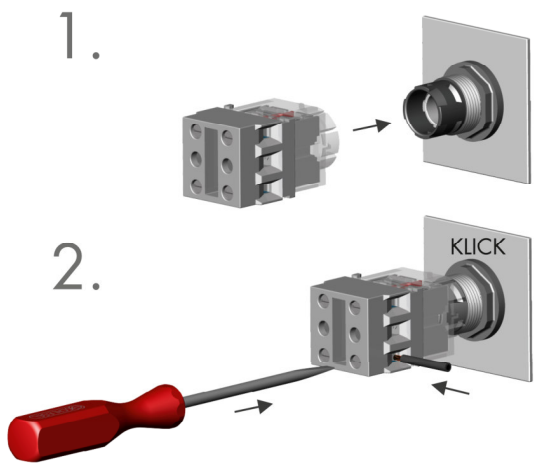

Fig. 6: connection BTK...

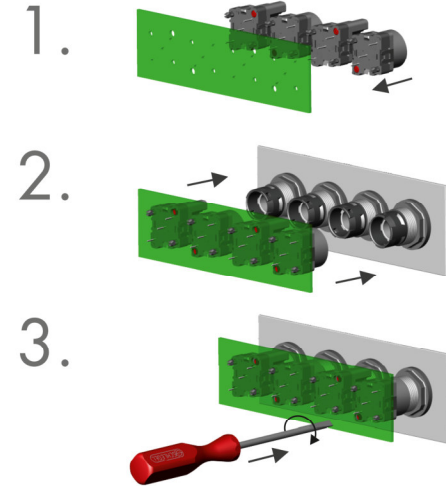

Fig. 9: PCB connection with bolt
The contact blocks PTP.../FRTP... may not be used as a single part. At least 2 contact blocks have to be mounted onto the PCB and they have to be arranged by 180° offset.

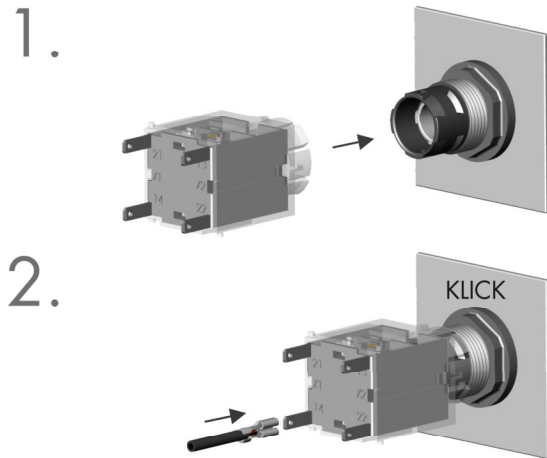

Fig. 7: connection AT... / AZ... / BT... /BZ...



Fig. 10: connection of M12 connect

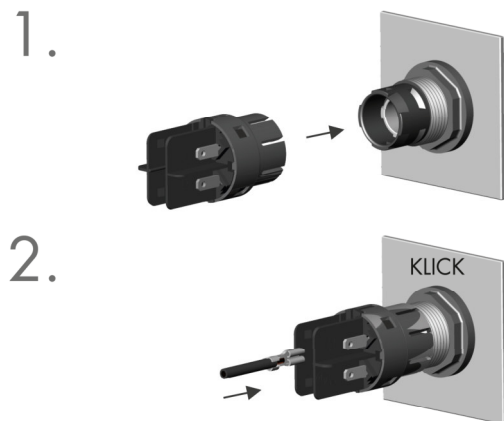

Fig. 8: connection PTF...

Emergency-stop/switch-off devices - mounting & operating instructions

(Translation of the original operating instructions)

V5.6, 21.05.2026, art.-no.: 615409900

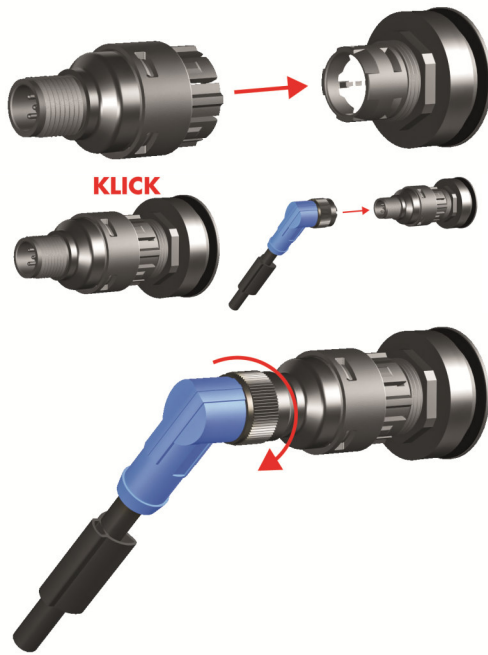

Fig. 11: connection FRT connect

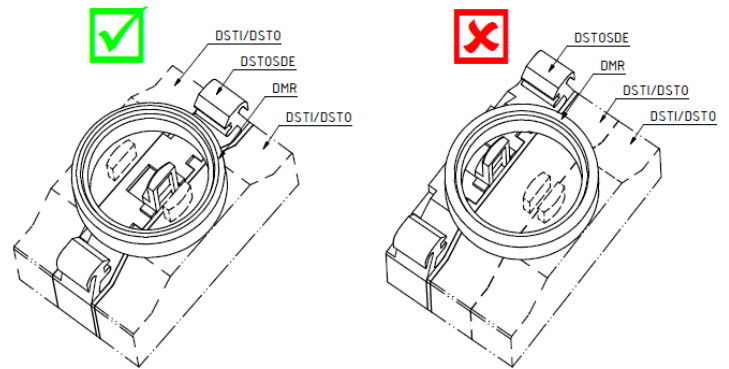

Fig. 13: DSTOSDE always to be mounted in the centre position

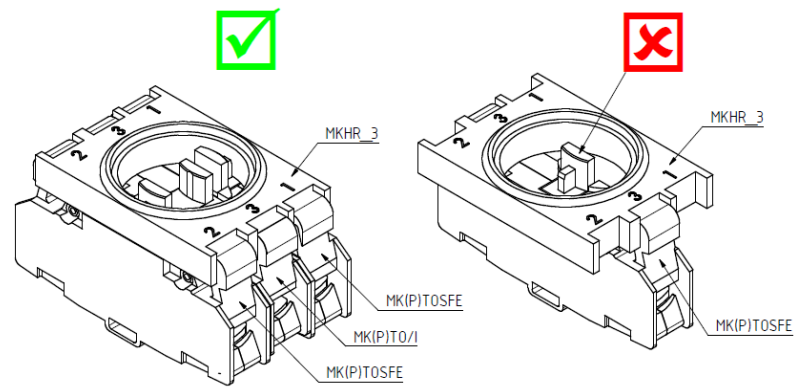

Fig. 14: MK(P)TOSFE can be mounted on position 1 and / or 2.

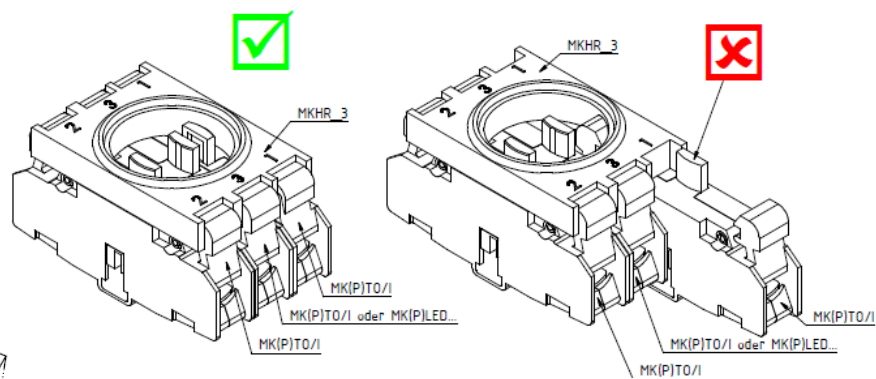

Fig. 15: The plunger may not be operated by the module holder MKHR_3.

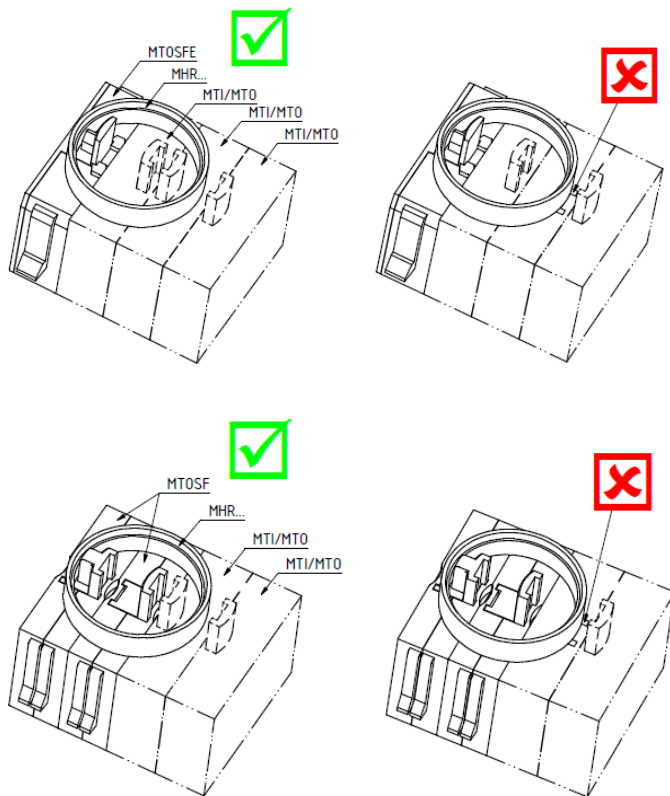

Fig. 12: The plunger of the MTOSF, MTOSFE may not be operated by the module holder